

SHIMPO WEST

RK-2 POTTER'S WHEEL

INSTRUCTION MANUAL



WITH THE WHEEL YOU SHOULD HAVE RECEIVED

- Wrench (10×13mm)

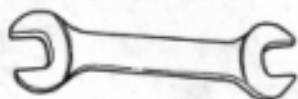

- Allen Wrench (5mm 3mm)

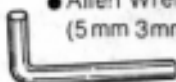

- T-Wrench

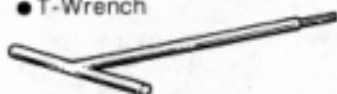

- Speed Control Pedal (Speed Control lever) & Bolts & Washers



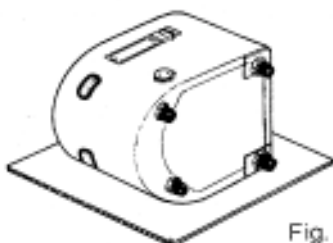

Fig. 1

1. Place wheel on its side with soft material underneath. (Fig. 1)

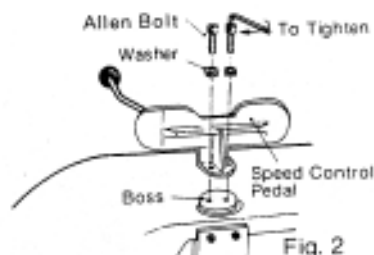

Fig. 2

2. Fix speed control pedal on Boss as shown in Fig. 2. Use the two Allen bolts and spring washers provided.

3. Remove red painted packing bolts and motor stabilizing bracket. (Fig. 3, 4a and 4b)

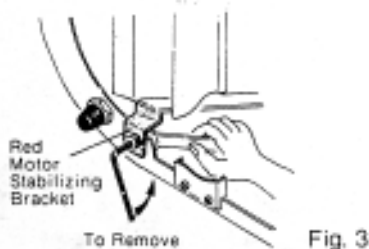

Fig. 3

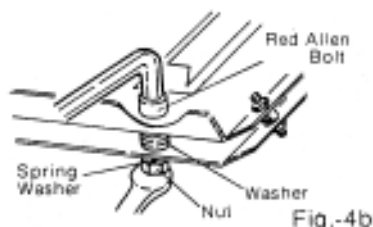

Fig. 4b

Note: These red bolts and nuts have been used to protect motor from damage that might be caused by rough handling during transportation. All these should be kept for future transportation.

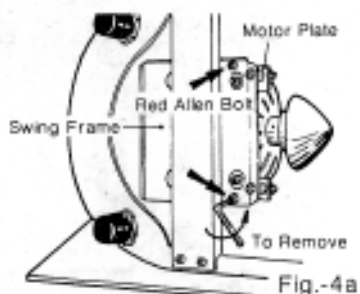

Fig. 4a

PLEASE ATTACH BOTTOM COVER NOW.

To attach bottom cover, see "HOW TO ATTACH BOTTOM COVER" on the last page.

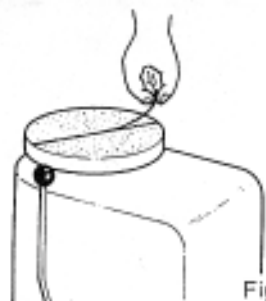

Fig. 5

After completing above operations, turn wheel to upright position.

4. Pull off string running across middle of wheel head and peel off plastic coating. (Fig. 5)
5. For the best results, wheel head should be leveled. This can be achieved by screwing in or out adjustable foot. When wheel is leveled, tighten lock nut on adjustable foot. (Fig. 6)

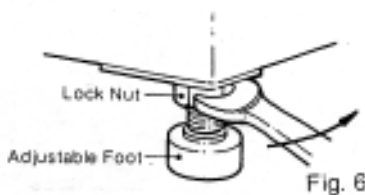
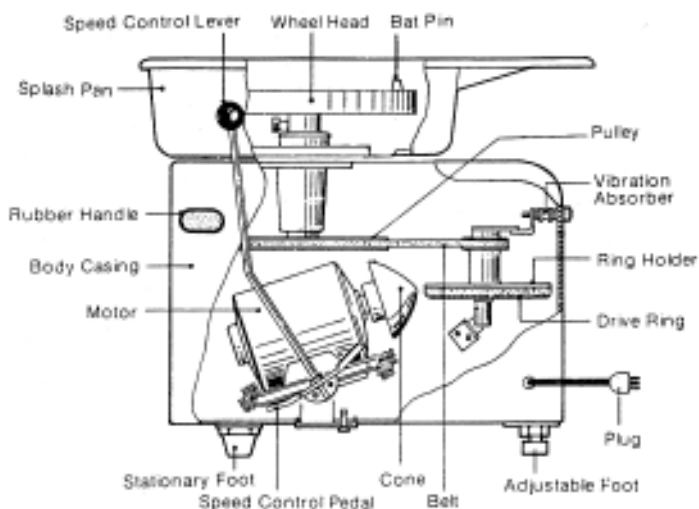

Fig. 6

DESCRIPTION OF PARTS



2

HOW TO OPERATE



Fig. 7

1. Plug in firmly.

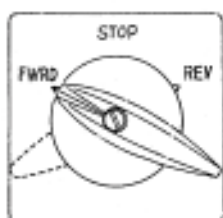

Fig. 8

FWRD : Counter Clockwise
REV : Clockwise

2. Turn switch ON. To change rotating direction from one to another, turn OFF switch and wait until motor stops completely. Then switch ON to desired direction.

Note: Do not attempt to change rotating direction while motor is still running, direction cannot be changed until motor is at complete stop.

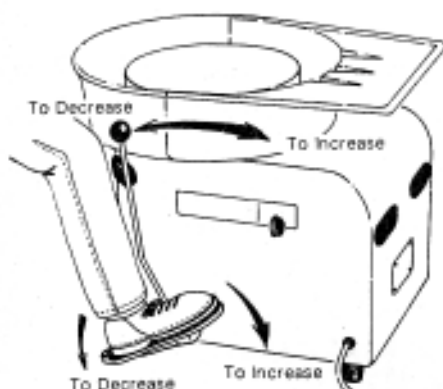

Fig. 9

3. To adjust speed, push speed control pedal FORWARD or BACKWARD to increase or decrease speed as desired.

4. Make sure pedal is all the way back in STOP position and motor is OFF when not in use.

Note: Failure to do so will cause temporary dent on rubber ring surface. If this happens rumbling will be heard when the wheel is operated again, but will disappear after a few minutes of operation.

3 REMOVING THE SPLASH PAN

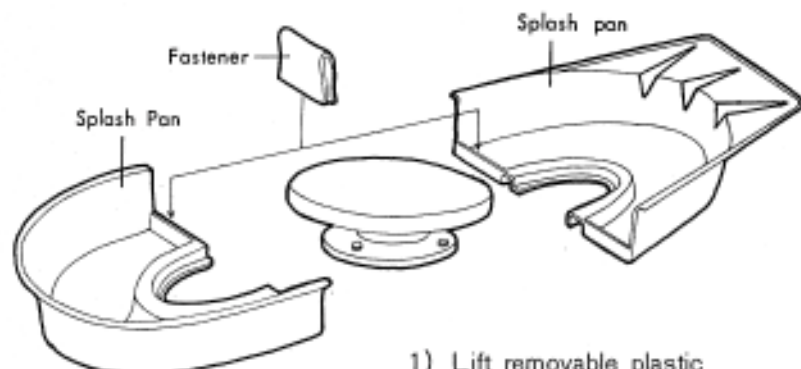

- 1) Lift removable plastic fasteners.
- 2) Pull out splash pan halves.

To reinstall splash pan, reverse the above procedure.

4 HOW TO ADJUST POWER

Pressure between drive ring and cone is initially adjusted to insure satisfactory performance. After a few years of extensive use, however, readjustment may become necessary. In this case, follow the instructions below.

1. Place the wheel as shown in Fig. 13.
2. Mark **A** with a pencil.
3. Loosen Allen bolt **B** two turns with Allen wrench.
4. Insert screwdriver at **C** to hold base-plate from slipping.
5. Loosen bolt **D** one turn.
6. Slide base-plate up $1/16$ " apart from mark **A** in step-1. Retighten bolt **D** after this is completed.
7. Follow same procedures in steps-3, 4, 5, but with bolt **E** instead of **D**.
8. Retighten all bolts.

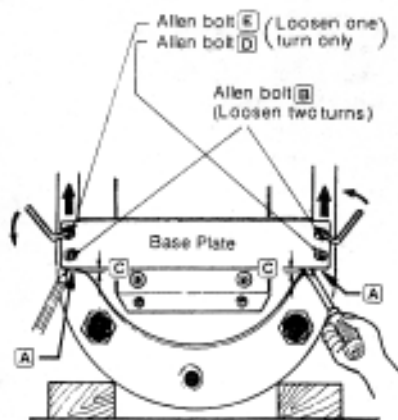

Fig. 13

Note: Do not slide base-plate unequal amount.

If unequally adjusted, speed control pedal may move itself and change speeds when you remove your foot from the pedal.

5 HOW TO REPLACE DRIVE BELT

Drive belt can last for a number of years under normal use. The following information is provided, if replacement is ever needed.

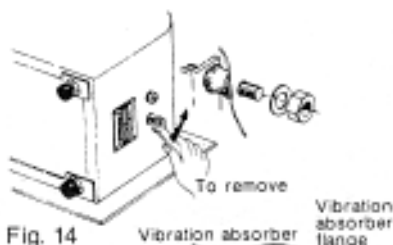

1. Remove splash pan and place wheel on its side. (Fig. 14)
2. Remove the hex. nuts and washers. (Fig. 14)



3. Pull out vibration absorber flange with absorbers from body case. (Fig. 15)

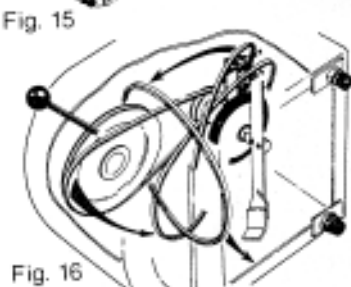

4. Remove drive belt from larger pulley first. (Fig. 16)
5. Reassemble in reverse sequence starting to place new drive belt from smaller pulley first. (Fig. 16)
6. After replacing drive belt, reinsert vibration absorber flange with absorbers and tighten two nuts firmly.

6 HOW TO REPLACE RUBBER RING

After several years under normal use, the rubber ring may become worn resulting in a lack of power.

If this happens, replace entire rubber ring.

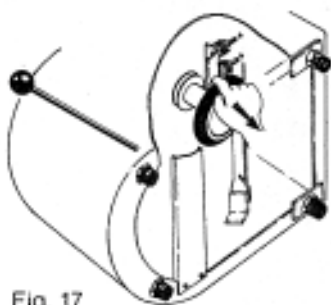

Note: Always check power adjustment before replacing rubber ring, most of the time this will resolve the problem.

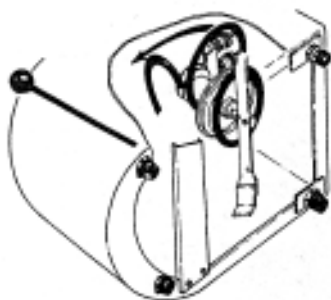

1. Remove splash pan and place wheel on its side. (Fig. 17)
2. Remove drive belt as instructed in Section 5, "How to Replace Drive Belt."
3. Slip old rubber ring off toward bottom of wheel from ring holder.
4. Remove rubber ring through ring holder. (Fig. 18)
5. Replace old ring with new one in reverse sequence.
6. After replacing rubber ring, refer to Section 5, Step 6 and 7 for final assembly.

SPECIFICATIONS

- Wheel head speed : 0-240 R.P.M
- Direction : Clockwise and counter-clockwise
- Material of wheel head : Light alloy casting
- Motor : 200W(1/4 Hp), 115V, 60Hz, Single Phase
- Dimensions : Length 622 mm(24-1/2")
Width 506 mm(20")
Height 499 mm(19-5/8")
Diameter of Wheel Head
300 mm(11-3/4")
- Weight : 40kg. (88lbs.)

SHIMPO CERAMICS DIVISION

NIDEC-SHIMPO AMERICA CORPORATION
1701 Glenlake Ave. • Itasca, IL 60143-1072
Ph: 630-924-7138 • Fax: 630-924-7639

Manufactured by

SHIMPO INDUSTRIAL CO., LTD.
KYOTO, JAPAN

PRINTED IN JAPAN